

MALLEABLE IRON/**HOT DIPPED GALVANIZED** MOGULS WITH COVER AND GASKET

FOR THREADED RIGID CONDUIT AND IMC

APPLICATION

- Larger body size facilitates pulling of large and heavy conductors. Specially designed raised cast covers provide additional wiring area.
- SEPCO Moguls are used for pulling straight, 45° or 90° angle turns and/or making taps and splices.

FEATURES

- Smooth, rounded integral bushing in each hub protects conductor insulation.
- Accurately tapered, tapered threads for tight, rigid joints and ground continuity.
- Covers have captive stainless steel screws to speed installation, prevent "freezing" of screws.
- Length Requirement: distance between centerline of each hub bushing (conduit stop) exceeds six times the trade diameter of the conduit per NEC 314.28(A)(2).

STANDARD MATERIALS

Bodies and Covers: Malleable Iron
Gaskets: Neoprene
Screws: Stainless Steel

STANDARD FINISH

Bodies and Covers: Hot-Dipped Galvanized

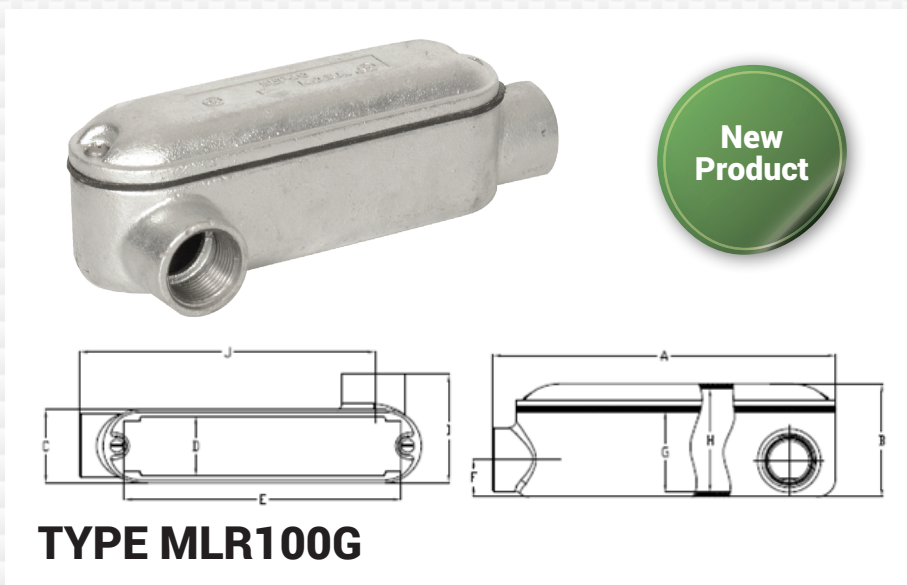

TYPE MLR100G

CATALOG NUMBER	TRADE SIZE	MAX WIRE SIZE	VOL. CU.IN.	UNIT PACK	MASTER PACK	LBS. / 100 PCS.	UPC#
MLR100G	1"	3 #4 AWG	31	-	1	176	10150
MLR125G	1-1/4"	3 #2 AWG	50	-	1	261	10151
MLR150G	1-1/2"	3 #1/0 AWG	93	-	1	435	10152
MLR200G	2"	3 #4/0 AWG	143	-	1	656	10153

CATALOG NUMBER	DIM A	DIM B	DIM C	DIM D	DIM E	DIM F	DIM G	DIM H	DIM I	DIM J	NUMBER OF COVER HOLES
MLR100G	8.94	2.80	2.36	1.85	6.61	0.93	1.84	2.48	3.27	7.76	2
MLR125G	11.16	3.44	2.44	1.93	7.60	1.14	2.28	3.13	3.39	9.94	2
MLR150G	13.27	3.88	3.15	2.56	9.68	1.34	2.57	3.46	4.00	11.69	2
MLR200G	17.02	4.43	3.15	2.52	13.09	1.63	3.14	4.02	4.13	15.45	2